

車載高功率晶片電阻器



特點 Features

- 高功率
High power
- 適用無鉛回流焊及波峰焊制程
Suit for reflow and wave soldering
- 符合車載 AEC-Q200 標準
Comply with the relevant provisions of AEC-Q200
- 符合 RoHS2.0 標準和 REACH 標準
RoHS2.0 compliant and REACH compliant

結構圖 Construction

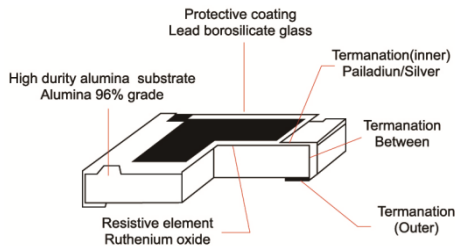

負載遞減曲線 Power Derating Curve

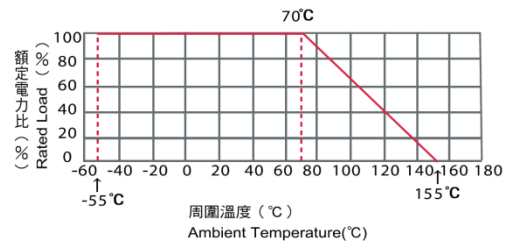

規格 Specifications

型 式 Type	定格電力 Rated power	最高使用電壓 Maximum working voltage	最高過負荷電壓 Maximum overload voltage	耐電壓 Dielectric Withstanding Voltage	阻值範圍(Ω) Resistance Range(Ω)
					±1%, ±2%, ±5%
0402	1/10W	50V	100V	50V	1Ω~1MΩ
0603	1/8W	75V	150V	100V	0Ω1~10MΩ
0805	1/4W	150V	300V	300V	0Ω1~10MΩ
1206	1/2W	200V	400V	500V	0Ω1~51MΩ
1210	3/4W	200V	400V	500V	0Ω1~51MΩ
2010	1W	200V	400V	500V	0Ω1~51MΩ
2512	2W	200V	400V	500V	0Ω1~51MΩ

尺寸 Dimension

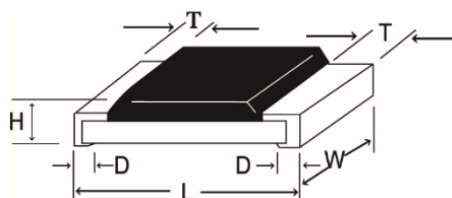

單位 Unit : mm

型式 Type	0402	0603	0805	1206	1210	2010	2512
公制	1005	1608	2012	3216	3225	5025	6432
L	1.0±0.1	1.6±0.1	2.0±0.15	3.1±0.15	3.1±0.1	5.0±0.15	6.35±0.2
W	0.5±0.05	0.8±0.15	1.25±0.15	1.6±0.15	2.6±0.15	2.5±0.15	3.2±0.15
H	0.35±0.05	0.45±0.1	0.55±0.1	0.55±0.1	0.55±0.1	0.55±0.1	0.55±0.1
T	0.2±0.1	0.3±0.15	0.4±0.2	0.45±0.2	0.5±0.2	0.6±0.2	0.6±0.2
D	0.25±0.1	0.3±0.2	0.4±0.2	0.5±0.20	0.5±0.20	0.6±0.2	0.6±0.2

車載高功率晶片電阻器

紙帶尺寸 Tape Specification

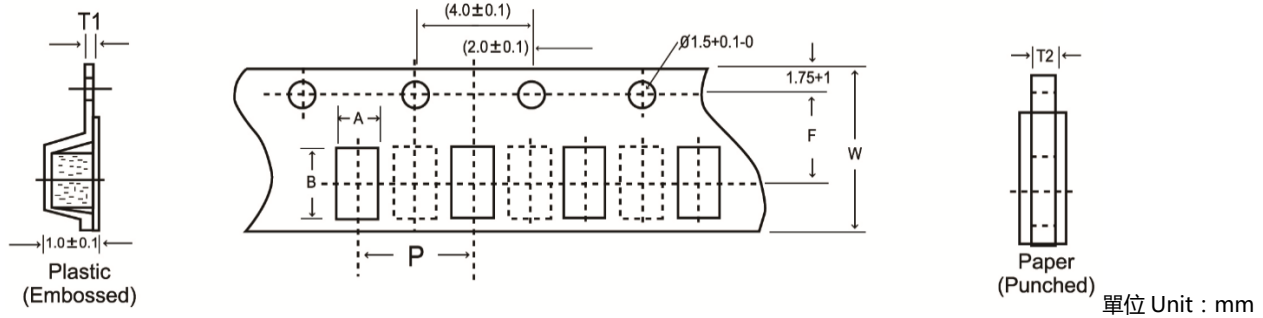

型式 Type	A	B	W	F	T1	T2	P
0402	0.65 ± 0.1	1.15 ± 0.1	8.0 ± 0.2	3.5 ± 0.05	-----	0.45 ± 0.1	2.0 ± 0.05
0603	1.10 ± 0.1	1.9 ± 0.1	8.0 ± 0.2	3.5 ± 0.05	-----	0.6 ± 0.1	4.0 ± 0.05
0805	1.65 ± 0.2	2.4 ± 0.2	8.0 ± 0.2	3.5 ± 0.05	-----	0.75 ± 0.1	4.0 ± 0.05
1206	2.0 ± 0.2	3.6 ± 0.2	8.0 ± 0.2	3.5 ± 0.05	-----	0.75 ± 0.1	4.0 ± 0.05
1210	2.8 ± 0.2	3.5 ± 0.2	8.0 ± 0.2	3.5 ± 0.05	-----	0.75 ± 0.1	4.0 ± 0.05
2010	2.9 ± 0.2	5.5 ± 0.2	12.0 ± 0.1	5.5 ± 0.5	0.2 ± 0.05	1.0 ± 0.1	4.0 ± 0.05
2512	3.6 ± 0.2	6.9 ± 0.2	12.0 ± 0.1	5.5 ± 0.5	0.2 ± 0.05	1.0 ± 0.1	4.0 ± 0.05

塑膠圓盤尺寸 Reel Dimensions

單位 Unit : mm

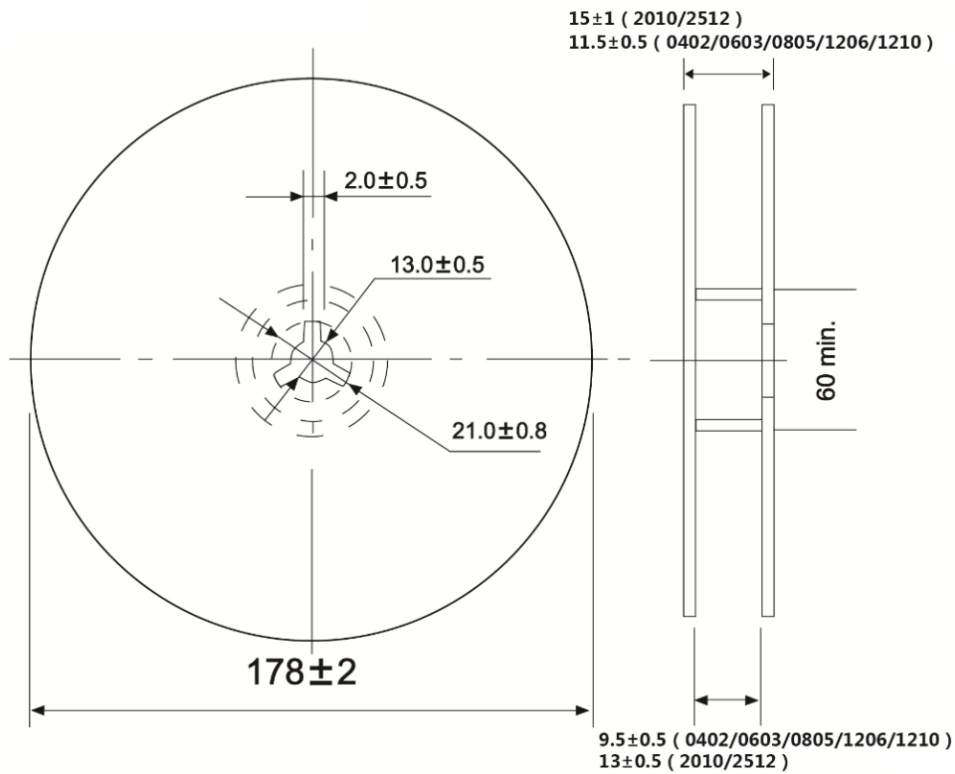

車載高功率晶片電阻器

品名構成 Product Identification

SMCH
↓
種類
Type

0805
↓
額定功率
Rated power

0402	0603	0805	1206
1210	2010	2512	

100R
↓
公稱電阻值
Nominal resistance

E-24 Series	E-48 Series	E-96 Series
----------------	----------------	----------------

F
↓
電阻值容許誤差
Resistance tolerance

F	G	J
±1%	±2%	±5%

特性 Characteristics

特性項目 Item	規格值 Performance	試驗方法(依據 JIS C 5201-1 或 AEC-Q200 Rev D) Test methods (Conform to JIS C 5201-1 or AEC-Q200 Rev D)
溫度係數 Temperature Coefficients	±1%, ±2%, ±5%: 0Ω ≤ R < 1Ω: ±600PPM/°C 1Ω ≤ R ≤ 10Ω: ±400PPM/°C 10Ω < R ≤ 10MΩ: ±100PPM/°C 10MΩ < R ≤ 51MΩ: ±200PPM/°C 0R: 50mΩ以下	JIS C 5201-1 4.8 項參照 Comply with 4.8 $\frac{R_1 - R_0}{R_0(T_1 - T_0)} \times 10^6$ (PPM/°C) R ₀ : 室溫(T ₀)所測量之電阻值。 R ₁ : 室溫+100°C(T ₁)後所測量之電阻值。 R ₀ : Resistance value at room temp(T ₀). R ₁ : Resistance value at room temp plus 100°C(T ₁).
短時間過負荷 Short Time Overload	±5% : ±(2%+0.1Ω) ±1% : ±(1%+0.05Ω) 0R : 50mΩ以下。 0R : 50mΩ or less. 不得有機械的損傷。 No evidence of mechanical damage.	JIS C 5201-1 4.13 項參照 Comply with 4.13 額定電壓 ×2.5 倍 5 秒， 不可超過最高過負荷電壓。 Rated voltage ×2.5 times 5s, But not to exceed maximum overload voltage.
絕緣電阻 Insulation Resistance	10 ³ MΩ以上。 10 ³ MΩ or more.	JIS C 5201-1 4.6 項參照 Comply with 4.6 施加直流電壓 100V 60 秒。 Resistor shall be tested at DC 100V for 60 Seconds.
耐濕負荷壽命 Load Life in Humidity	±1% : ±(1.0%+0.05Ω)以內。 ±5% : ±(3.0%+0.10Ω)以內。 0R : 50mΩ以下。 Within 1% : ±(1.0%+0.05Ω). Within 5% : ±(3.0%+0.10Ω). 0R : 50mΩ or less.	AEC-Q200-REV C-Test 6 MIL-STD-202 Method 106 JIS C 5201-1 4.24 項參照 Comply with 4.24 40±2°C, 濕度 90~95%, 1000 小時 定格電壓(90 分鐘 ON, 30 分鐘 OFF). 40±2°C, 90 to 95%RH, 1000h Rated voltage (90 min ON, 30 min OFF).
耐電壓 Dielectric Withstanding Voltage	無電弧放電、燒損及絕緣破壞等異狀。 No evidence of flashover mechanical damage, arcing or insulation breakdown.	JIS C 5201-1 4.7 項參照 Comply with 4.7 施加個別規定之交流電壓 60 秒。 Resistor shall be tested at AC potential respectively for 60 seconds.
溫度循環 Temperature Cycle	±(1%+0.05Ω)以內。 0R : 50mΩ以下 不得有機械的損傷。 Within ±(1%+0.05Ω) 0R : 50mΩ or less. No evidence of mechanical damage.	AEC-Q200-REV D-Test 4 參照 JESD22 JA-104 項規定 1000 個循環 (-55°C 到 +125°C)。 試驗結束後 24±4 小時內進行測試。 每個溫度的停留時間不超過 30 分鐘。 轉換時間不超過 1 分鐘。 Reference JESD22 Method JA-104 1000 Cycles (-55°C to +125°C) Measurement at 24±4 hours after test conclusion. 30min maximum dwell time at each temperature extreme. 1 min. maximum transition time.

車載高功率晶片電阻器

<p>偏高濕度 Biased Humidity</p>		<p>AEC-Q200-REV D-Test 7 參照 MIL-STD-202 103 項規定 在溫度 85°C 濕度 85% 的條件下放置 1000 小時注意指定條件工作電源的 10% 試驗結束後 24±4 小時內進行測試：SMD 0402 1/16W-1M F 施加 5V、SMD 1206 1/4W-100K F 施加 15.8V、SMD 2512 1W-3.3 J 施加 1.81V Reference MIL-STD-202 Method 103 1000 hours 85°C 85%RH. Note: Specified conditions: 10% of operating power. Measurement at 24±4 hours after test conclusion.</p>
<p>負荷壽命 Load Life</p>	<p>±1% : ±(1.0%+0.05Ω) 以內。 ±5% : ±(3.0%+0.10Ω) 以內。 Within 1% : ±(1.0%+0.05Ω). Within 5% : ±(3.0%+0.10Ω).</p>	<p>AEC-Q200-REV D-Test 8 MIL-STD-202 Method 108 JIS C 5201-1 4.25.1 項參照 Comply with 4.25.1 70±3°C, 1000 小時 定格電壓(90 分鐘 ON, 30 分鐘 OFF) 70±3°C, 1000h Rated voltage (90 min ON, 30 min OFF)</p>
<p>溶劑抵抗 Resistance to Solvents</p>	<p>字碼和保護層不能分離 Marking and protective layer Cannot be detached</p>	<p>AEC-Q200-REV D-Test 12 MIL-STD-202 Method 215 a: Isopropyl Alcohol : Mineral Spirits = 1 : 3 b: Terpene Defluxer (Bioact EC-7R) c: Deionized water : Propylene Glycol Monomethyl Ether : monoethanolamine = 42 : 1 : 1</p>
<p>機械衝擊 Mechanical Shock</p>	<p>±(1% + 0.1Ω) 0Ω: 50mΩ or less</p>	<p>AEC-Q200-REV D-Test 13 MIL-STD-202-213 Wave Form : Tolerance for half sine shock Pulse : Peak value is 100g' s. Normal duration(D) is 6ms</p>
<p>震動 Vibration</p>	<p>±(1% + 0.1Ω) 0Ω: 50mΩ or less</p>	<p>AEC-Q200-REV D-Test 14 參照 MIL-STD-202 204 項規定 5 g's 的力 20 分鐘，三個方向每個方向 12 個循環。 注意：使用 8" X 5" 印刷線路板，.031" 厚，在長的一邊有 7 個固定點，在對面的邊的角有 2 個固定點。產品在距離固定點 2" 內安裝。 測試頻率從 10~2000 赫茲。 MIL-STD-202 Method 204 5 g's for 20min , 12 cycles each of 3 orientations. Note : Use 8" X 5" PCB .031" thick 7 secure points on one long side and 2 secure points at corners of opposite sides. Parts mounted within 2" from any secure point. Test from 10~2000Hz.</p>
<p>抗焊接熱 Resistance to Soldering Heat</p>		<p>AEC-Q200-REV D-Test 15 參照 MIL-STD-202 210 項規定 條件 B，樣品不進行預熱。注意：單一波峰焊-表面貼裝元件，按程序 2：引腳產品按程序 1 進行焊接，浸入器件本體的 1.5mm 的深度。 Reference MIL-STD-202 Method 210 Condition B No pre-heat of samples. Note : Single Wave Solder – Procedure 2 for SMD and Procedure 1 for Leaded with solder within 1.5mm of device body.</p>
<p>熱衝擊 Thermal Shock</p>	<p>±(1% + 0.1Ω) 0Ω: 50mΩ or less</p>	<p>AEC-Q200-REV D-Test 16 MIL-STD-202 Method 107 -55°C/+155°C. Note: Number of cycles required : 300cycles, Maximum transfer time : 20seconds, Dwell time : 15 minutes. Air-Air.</p>
<p>ESD 靜電放電</p>	<p>±(1% + 0.1Ω) 0Ω: 50mΩ or less</p>	<p>AEC-Q200-REV D-Test 17 DIS10605 verify the voltage setting at 500V</p>
<p>可焊性 Solder Ability</p>	<p>0.5%, 1%: ±(0.5% + 0.05Ω) 2%. 5%: ±(1% + 0.1Ω) 0Ω: 50mΩ or less</p>	<p>AEC-Q200-REV D-Test 18 J-STD-002 Condition B: Immerse the specimens in and eutectic solder at 260±5°C for 10±1S.</p>
<p>電氣特性 Electrical Characterization</p>		<p>AEC-Q200-REV D-Test 19 GB/T 5729-2003 4.8 參照產品規格書 按批次和樣品數量要求進行參數試驗，總結列出室溫下及最低，最高工作溫度下器件的最小值，最大值，平均值和標準偏差。 Reference User Spec. Parametrically test per lot and sample size requirements , summary to show Min , Max , Mean and Standard deviation at room as well as Min and Max operating temperatures.</p>

車載高功率晶片電阻器

<p>可燃性 Flammability</p>		<p>AEC-Q200-REV D-Test 20 參照 UL-94 V-0 或 V-1 可接受。不需要電氣測試。 Reference UL-94 V-0 or V-1 are acceptable. Electrical test not required.</p>
<p>彎折性 Bending Strength</p>	<p>0.5%,1%: $\pm (0.5\% + 0.05\Omega)$ 2%.5%: $\pm (1\% + 0.1\Omega)$ 0Q: 50mΩ or less</p>	<p>AEC-Q200-REV D-Test 21 3mm deflection (0402~1210) 2mm deflection (2010~2512) 參照 AEC Q200-005 至少 60 秒的支撐時間。 Reference AEC Q200-005 60 sec minimum holding time</p>
<p>端子強度 (表面貼裝元件) Terminal Strength(SMD)</p>		<p>AEC-Q200-REV D-Test 22 參照 AEC Q200-006 器件安裝在由供應商處獲得的 PCB 板, 器件已進行測試, 施加一個 17.7 牛(1.8kg)的力到測試器件的側面。此外力的施加時間為 60+1 秒。同樣, 這個力要慢慢地施加, 以免測試器件受到震動。 Reference AEC Q200-006 With the component mounted on a PCB obtained from the Supplier with the device to be tested, apply a 17.7N(1.8Kg) force to the side of a device being tested. This force shall be applied for 60+1 seconds. Also the force shall be applied gradually as not to apply a shock to the component being tested.</p>
<p>焊錫附著性 Solderability</p>	<p>電極至少 95%以上新錫覆蓋。 Electrode with new solder by 95% at least.</p>	<p>JIS C 5201-1 4.17 項參照 Comply with 4.17 焊錫溫度: 245\pm5$^{\circ}$C 浸錫時間: 3~5 秒 Test temperature of solder: 245\pm5$^{\circ}$C Dipping time in solder: 3~5 seconds</p>
<p>焊錫耐熱性 Resistance to Soldering Heat</p>	<p>$\pm(1\%+0.05\Omega)$以內。 0R: 50mΩ以下。 不得有機械的損傷。 Within $\pm(1\%+0.05\Omega)$. 0R: Less than 50mΩ. No evidence of mechanical damage.</p>	<p>JIS C 5201-1 4.18 項參照 Comply with 4.18 260\pm5$^{\circ}$C, 10\pm1.0 秒, 試驗後放置半小時。 260\pm5$^{\circ}$C, 10\pm1.0 seconds, After test leave for 0.5h.</p>
<p>電烙鐵試驗 Electric Iron Test</p>	<p>阻值範圍: $\geq 1\Omega$ $\Delta R\% = \pm(1.0\%+0.05\Omega)$電極外觀無異常, 無側導脫落。 $\Delta R\% = \pm(1.0\%+0.05\Omega)$ No evidence of electrode damage, No sides conductive peel off.</p>	<p>加熱溫度: 350$^{\circ}$C\pm5$^{\circ}$C, 電烙鐵加熱時間 3+1/-0 秒, 取電烙鐵加熱於電極兩端后, 取出靜置 60 分鐘以上, 再量測其阻值變化率。 Preheating temperature: 350$^{\circ}$C\pm5$^{\circ}$C Electric iron preheating time: 3+1/-0sec Preheat the electric iron on electrode termination, as after that step place the iron over 60mins and measure its resistance rate.</p>

公司名稱 Company Name	彩源企業股份有限公司 彩智電子科技(江西)有限公司 TZAI YUAN ENTERPRISE CO., LTD.				
品名 Product Name	車載高功率晶片電阻器 High-power Chip Resistors for Automobile				
版本 Version	A4 版	制定日期 Enactment Date	2026 年 01 月 06 日 Jan.06,2026	頁數 Page	16-1

1. 一般事項 General

1.1 適用 Scope

本承認書適用於 彩源企業股份有限公司 製造之[車載高功率晶片電阻器] 無鉛產品。
This specification is available for High-power Chip Resistors for automobile manufactured by TZAI YUAN ENTERPRISE CO., LTD. Pb Free。

1.2 形名(例) Type designation (example)

依使用種類、額定電力、公稱電阻值、容許誤差及形狀而區別,其構造如下。
The type designation shall be in the following form and as specified.

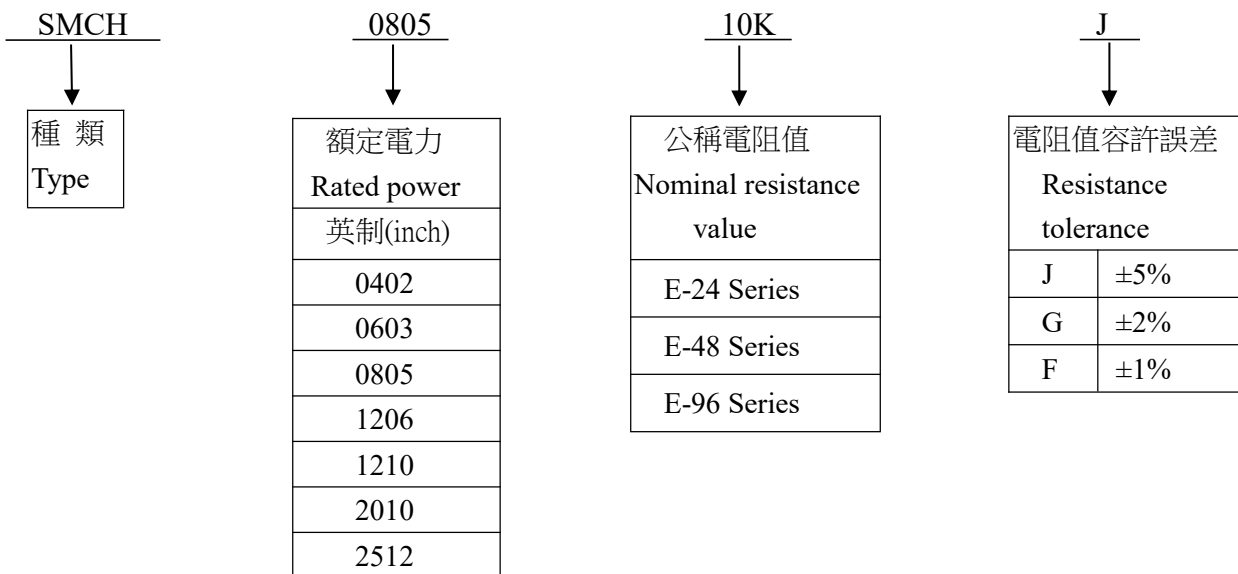

1.3 額定電力 Rated power

額定電力係應在周圍溫度 70°C 可以連續負載的最大電力, 如表-1;但周圍溫度如超過 70°C 時之額定電力則依圖一的電力遞減曲線實施。

Rated power is maximum power which can be continuously loaded at specified ambient temperature 70°C, as Table-1; however when the ambient temperature exceeds 70°C, rated power should be determined from the derating curve of Fig.1.

公司名稱 Company Name	彩源企業股份有限公司 彩智電子科技(江西)有限公司 TZAI YUAN ENTERPRISE CO., LTD.				
品名 Product Name	車載高功率晶片電阻器 High-power Chip Resistors for Automobile				
版本 Version	A4 版	制定日期 Enactment Date	2026 年 01 月 06 日 Jan.06,2026	頁數 Page	16-2

表-1 Table-1

型式 Type	定格電力 Rated power	最高使用電壓 Maximum working voltage	最高過負荷電壓 Maximum overload voltage	耐電壓 Dielectric Withstanding Voltage	阻值範圍(Ω) Resistance Range(Ω)
					±1%,±2,±5%
0402	1/10W	50V	100V	50V	1Ω~1MΩ
0603	1/8W	75V	150V	100V	0Ω1~10MΩ
0805	1/4W	150V	300V	300V	0Ω1~10MΩ
1206	1/2W	200V	400V	500V	0Ω1~51MΩ
1210	3/4W	200V	400V	500V	0Ω1~51MΩ
2010	1W	200V	400V	500V	0Ω1~51MΩ
2512	2W	200V	400V	500V	0Ω1~51MΩ

備註：①以上表格中最高使用電壓：按照公式 $E=\sqrt{P \times R}$ 計算出最高工作電壓；當計算的電壓小於表-1 中最高使用電壓時，以計算的電壓為準；當計算的電壓大於表-1 中最高使用電壓時，以表-1 中最高使用電壓為準。

①Note: In the above table top use voltage: according to the formula $E = \sqrt{P \times R}$ calculated the highest working voltage, When calculating the voltage is less than form Table-1 in the highest use voltage, standard as the voltage calculated, When calculating the voltage is greater than the highest voltage of form Table- 1, standard as highest voltage of form Table-1 .

②超出表格規定阻值 10MΩ 以上，如客戶有需求時必須提供相關參數參考，以利測試。

② Beyond the form specified value 10M Ω above, such as customer demand to provide related reference, in order to test.

③電阻值測量標準狀態 符合 JIS C 5201-1 4.5 規定：

③All of the resistance measurement according to JIS C 5201-1 4.5 standard regulations.

表-2 Table-2 (0Ω resistance become Less than 50mΩ)

型式 Type	定格電力 Rated power	最大額定電流 Maximum working current	最大過負荷電流 Maximum overload current	阻值範圍(mΩ) Resistance Range(mΩ)
0402	1/10W	1.41A	3.52A	50mΩ MAX
0603	1/8W	1.58A	3.95A	50mΩ MAX
0805	1/4W	2.24A	5.6A	50mΩ MAX
1206	1/2W	3.16A	7.9A	50mΩ MAX
1210	3/4W	3.87A	9.68A	50mΩ MAX
2010	1W	4.47A	11.2A	50mΩ MAX
2512	2W	6.32A	15.8A	50mΩ MAX

備註：表-2 為 0Ω 專用 (0Ω 即電阻值為 50mΩ 以下)

Note: Table -2 is 0Ω-specific (0Ω resistance become Less than 50mΩ)

公司名稱 Company Name	彩源企業股份有限公司 彩智電子科技(江西)有限公司 TZAI YUAN ENTERPRISE CO., LTD.				
品名 Product Name	車載高功率晶片電阻器 High-power Chip Resistors for Automobile				
版本 Version	A4 版	制定日期 Enactment Date	2026 年 01 月 06 日 Jan.06,2026	頁數 Page	16-3

圖一 電力遞減曲線 Figure 1 Power derating curve

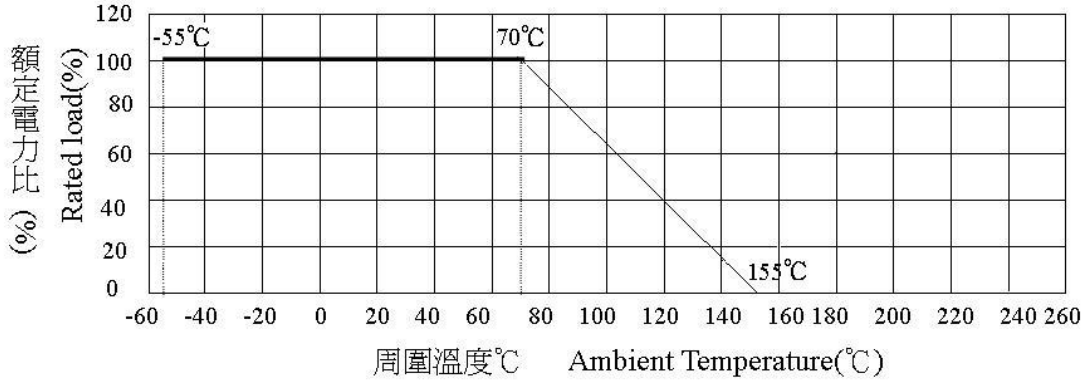

備註：使用溫度範圍：-55°C~+155°C (0402、0603、0805、1206、1210、2010、2512)
 Note: Operating Temperature Range: -55°C~+155°C (0402、0603、0805、1206、1210、2010、2512)

1.4 額定電壓 Rated voltage

額定電壓係指對應於額定電力的直流或交流(商用頻率之有效值)的電壓(見表-1)，由下式求得。
 The rated voltage shall be the D.C. or A.C.(R.M.S. at power frequency) voltage which corresponds the rated power and the value of which is calculated from the formula below.

$$E = \sqrt{P \times R} \quad \text{Where} \quad \begin{array}{ll} E: \text{ 定格電壓} & \text{Rated voltage(V)} \\ P: \text{ 定格電力} & \text{Rated power(W)} \\ R: \text{ 公稱電阻值} & \text{Nominal resistance(\Omega)} \end{array}$$

1.5 額定電流 Rated current

額定電流係指對應於額定電力的直流或交流(商用頻率之有效值)的電流(見表-2)，阻值範圍：50mΩ以下由下式求得。

The rated voltage shall be the D.C. or A.C.(R.M.S. at power frequency) voltage which corresponds the rated power and the value of which is calculated from the formula below.

$$I = \sqrt{P/R} \quad \text{Where} \quad \begin{array}{ll} I: \text{ 定格電流} & \text{Rated current(A)} \\ P: \text{ 定格電力} & \text{Rated power(W)} \\ R: \text{ 公稱電阻值} & \text{Nominal resistance(\Omega)} \end{array}$$

2. 特性 Characteristics

項目 Item	規格值 Performance	試驗方法(依據 JIS C 5201-1 或 AEC-Q200 Rev D) Test methods(Conform to JIS C 5201-1 or AEC-Q200 Rev D)
溫度係數 Temperature Coefficient	±1%, ±2%, ±5%: 0Ω ≤ R < 1Ω: ±600PPM/°C 1Ω ≤ R ≤ 10Ω: ±400PPM/°C 10Ω < R ≤ 10MΩ: ±100PPM/°C 10MΩ < R ≤ 51MΩ: ±200PPM/°C 0R: 50mΩ以下	JIS C 5201-1 4.8 項參照 Comply with 4.8 $\frac{R_1 - R_0}{R_0(T_1 - T_0)} \times 10^6 (\text{PPM}/^\circ\text{C})$ R ₀ : 室溫(T ₀)所測量之電阻值。 R ₁ : 室溫+100°C(T ₁)後所測量之電阻值。 R ₀ : Resistance value at room temp. (T ₀). R ₁ : Resistance value at room temp. plus 100°C (T ₁)

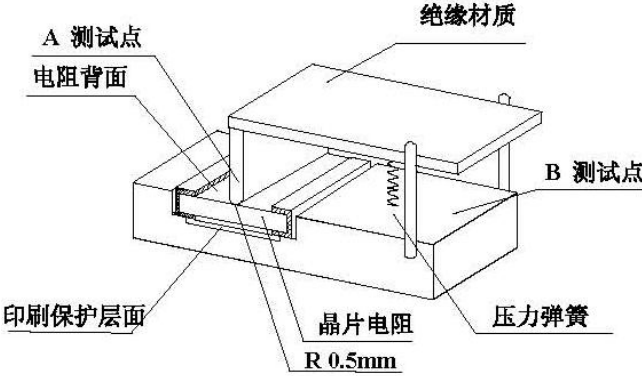
公司名稱 Company Name		彩源企業股份有限公司 彩智電子科技(江西)有限公司 TZAI YUAN ENTERPRISE CO., LTD.			
品名 Product Name		車載高功率晶片電阻器 High-power Chip Resistors for Automobile			
版本 Version	A4 版	制定日期 Enactment Date	2026 年 01 月 06 日 Jan.06,2026	頁數 Page	16-4
項目 Item	規格值 Performance	試驗方法(依據 JIS C 5201-1 或 AEC-Q200 Rev D) Test methods(Conform to JIS C 5201-1 or AEC-Q200 Rev D)			
短時間過負荷 Short time Overload	$\pm 5\%:\pm(2\%+0.1\Omega)$; $\pm 1\%:\pm(1\%+0.05\Omega)$ 0R:50m Ω 以下 不得有機械的損傷。 No evidence of mechanical damage.	JIS C 5201-1 4.13 項參照 Comply with 4.13 額定電壓 $\times 2.5$ 倍,5 秒。 不可超過最高過負荷電壓(見表-1) Rated voltage $\times 2.5$ times,5s But not to exceed maximum overload voltage. (See table-1)			
絕緣電阻 Insulation Resistance	$10^3\text{M}\Omega$ 以上。 $10^3\text{M}\Omega$ or more.	JIS C 5201-1 4.6 項參照 Comply with 4.6 施加直流電壓 100V 60 秒  Resistor shall be tested at DC 100V for 60 seconds			
耐濕負荷壽命 Load life in humidity	$\pm 1\%:\pm(1.0\%+0.05\Omega)$ 以內 $\pm 5\%:\pm(3.0\%+0.10\Omega)$ 以內 0R:50m Ω 以下 Within1%: $\pm(1.0\%+0.05\Omega)$ Within5%: $\pm(3.0\%+0.10\Omega)$ R:50m Ω 以下	4.24 項參照 Comply with 4.24 $40\pm 2^\circ\text{C}$, 濕度 90~95%, 1000 小時 定格電壓(90 分鐘 ON, 30 分鐘 OFF) $40\pm 2^\circ\text{C}$, 90 to 95%RH, 1000h Rated voltage (90 min ON, 30 min OFF)			
耐電壓 Dielectric Withstanding Voltage	無電弧放電、燒損及絕緣破壞等異狀。 No evidence of flashover mechanical damage, arcing or insulation breakdown.	4.7 項參照 Comply with 4.7 施加個別規定之交流電壓 60 秒。(見表-1) Resistor shall be tested at AC potential respectively for 60 seconds. (See table 1)			

公司名稱 Company Name		彩源企業股份有限公司 彩智電子科技(江西)有限公司 TZAI YUAN ENTERPRISE CO., LTD.			
品名 Product Name		車載高功率晶片電阻器 High-power Chip Resistors for Automobile			
版本 Version	A4 版	制定日期 Enactment Date	2026 年 01 月 06 日 Jan.06,2026	頁數 Page	16-5
項目 Ite	規格值 Performance	試驗方法(依據 JIS C 5201-1 或 AEC-Q200 Rev D) Test methods(Conform to JIS C 5201-1 or AEC-Q200 Rev D)			
應力測試 前、後電氣 測試 Pre-and Post-Stress Electrical Test		AEC-Q200-REV D-Test 1 GB/T 5729-2003 4.5 參照產品規格書 需進行測試，除了適用的應力測試標準和表 7 中的附加要求指定之外。 Reference: User Spec. Test is performed except as specified in the applicable stress reference and the additional requirements in Table 7			
高溫存儲 High Temperature Exposure (Storage)		AEC-Q200-REV D-Test 3 參照 MIL-STD-202 108 項規定 1000 小時@ T=125°C 不通電試驗結束後 24±4 小時內進行測試。 Reference MIL-STD-202 Method 108 1000 hrs. @ T=125 °C Unpowered Measurement at 24±4 hours after test conclusion.			
溫度循環 Temperature cycle	±(1%+0.05Ω)以內。 0R:50mΩ以下 不得有機械的損傷。 Within ±(1%+0.05Ω) 0R:50mΩ以下 No evidence of mechanical damage.	AEC-Q200-REV D-Test 4 參照 JESD22 JA-104 項規定 1000 個循環 Cycles(-55°C 到 +125°C)。 試驗結束後 24±4 小時內進行測試。 每個溫度的停留時間不超過 30 分鐘。 轉換時間不超過 1 分鐘。 Reference JESD22 Method JA-104 1000 Cycles(-55°C to +125°C) Measurement at 24±4 hours after test conclusion. 30min maximum dwell time at each temperature extreme. 1 min. maximum transition time.			
偏高濕度 Biased Humidity		AEC-Q200-REV D-Test 7 參照 MIL-STD-202 103 項規定 在溫度 85°C 濕度 85%的條件下放置 1000 小時注意指定條件工作電源的 10%試驗結束後 24±4 小時內進行測試：SMD 0402 1/16W-1M F 施加 5V SMD 1206 1/4W-100K F 施加 15.8V SMD 2512 1W-3.3 J 施加 1.81V Reference MIL-STD-202 Method 103 1000 hours 85°C 85%RH.Note: Specified conditions:10% of operating power. Measurement at 24±4 hours after test conclusion.			

公司名稱 Company Name	彩源企業股份有限公司 彩智電子科技(江西)有限公司 TZAI YUAN ENTERPRISE CO., LTD.				
品名 Product Name	車載高功率晶片電阻器 High-power Chip Resistors for Automobile				
版本 Version	A4 版	制定日期 Enactment Date	2026 年 01 月 06 日 Jan.06,2026	頁數 Page	16-6
項目 Item	規格值 Performance	試驗方法(依據 JIS C 5201-1 或 AEC-Q200 Rev D) Test methods(Conform to JIS C 5201-1 or AEC-Q200 Rev D)			
負荷壽命 Load Life	±1%:±(1.0%+0.05Ω)以內 ±5%:±(3.0%+0.10Ω)以內 Within1%:±(1.0%+0.05Ω) Within5%:±(3.0%+0.10Ω)	AEC-Q200-REV D-Test 8 MIL-STD-202 Method 108 JIS C 5201-1 4.25.1 項參照 Comply with 4.25.1 70±3°C, 1000 小時 定格電壓(90 分鐘 ON, 30 分鐘 OFF) 70±3°C, 1000h Rated voltage (90 min ON, 30 min OFF)			
外觀 External Visual		AEC-Q200-REV D-Test 9 參照 MIL-STD-883 2009 項規定 檢查器件結構標識和工藝質量, 不要求電氣測試。 Reference MIL-STD-883 Method 2009 Electrical test not required. Inspect device construction, marking and workmanship.			
尺寸 Physical Dimension		AEC-Q200-REV D-Test 10 參照 JESD22 JB-100 項規定 按適用的器件詳細規格驗證物理尺寸。 注意: 用戶和供應商規格, 不要求電氣測試。 Reference JESD22 Method JB-100 Verify physical dimensions to the applicable device detail specification. Note: User(s) and Suppliers spec. Electrical test not required.			
溶劑抵抗 Resistance to Solvents	Marking and protective layer Cannot be detached	AEC-Q200-REV D-Test 12 MIL-STD-202 Method 215 a:Isopropyl Alcohol : Mineral Spirits= 1 : 3 b:Terpene Defluxer (Bioact EC-7R) c:Deionized water : Propylene Glycol Monomethyl Ether : monoethanolamine =42 : 1 : 1			
機械衝擊 Mechanical Shock	±(1% + 0.1Ω) 0Ω : 50mΩ or less	AEC-Q200-REV D-Test 13 MIL-STD-202-213 Wave Form : Tolerance for half sine shock Pulse : Peak value is 100g's. Normal duration(D) is 6(ms)			

公司名稱 Company Name		彩源企業股份有限公司 彩智電子科技(江西)有限公司 TZAI YUAN ENTERPRISE CO., LTD.			
品名 Product Name		車載高功率晶片電阻器 High-power Chip Resistors for Automobile			
版本 Version	A4 版	制定日期 Enactment Date	2026 年 01 月 06 日 Jan.06,2026	頁數 Page	16-7
項目 Item	規格值 Performance	試驗方法(依據 JIS C 5201-1 或 AEC-Q200 Rev D) Test methods(Conform to JIS C 5201-1 or AEC-Q200 Rev D)			
震動 Vibration	$\pm(1\% + 0.1\Omega)$ 0 Ω : 50m Ω or less	AEC-Q200-REV D-Test 14 參照 MIL-STD-202 204 項規定 5 g's 的力 20 分鐘，三個方向每個方向 12 個循環。 注意：使用 8"X 5"印刷線路板，.031" 厚，在長的一邊有 7 個固定點，在對面的邊的角有 2 個固定點。產品在距離固定點 2" 內安裝。測試頻率從 10~2000 赫茲。 MIL-STD-202 Method 204 5 g's for 20min , 12 cycles each of 3 orientations. Note : Use 8"X 5"PCB .031"thick 7 secure points on one long side and 2 secure points at corners of opposite sides. Parts mounted within 2" from any secure point. Test from 10~2000Hz.			
抗焊接熱 Resistance to Soldering Heat		AEC-Q200-REV D-Test 15 參照 MIL-STD-202 210 項規定 條件 B, 樣品不進行預熱。注意：單一波峰焊-表面貼裝元件，按程序 2；引腳產品按程序 1 進行焊接，浸入器件本體的 1.5mm 的深度。 Reference MIL-STD-202 Method 210 Condition B No pre-heat of samples. Note :Single Wave Solder – Procedure 2 for SMD and Procedure 1 for Leaded with solder within 1.5mm of device body.			
熱衝擊 Thermal Shock	$\pm(1\% + 0.1\Omega)$ 0 Ω : 50m Ω or less	AEC-Q200-REV D-Test 16 MIL-STD-202 Method 107 -55°C/+155°C. Note: Number of cycles required : 300cycles, Maximum transfer time : 20seconds, Dwell time : 15 minutes. Air-Air			
ESD 靜電放電	$\pm(1\% + 0.1\Omega)$	AEC-Q200-REV D-Test 17 DIS10605 verify the voltage setting at 500V			
可焊性 Solder ability	0.5%,1% : $\pm(0.5\% + 0.05\Omega)$ 2%.5% : $\pm(1\% + 0.1\Omega)$ 0 Ω : 50m Ω or less	AEC-Q200-REV D-Test 18 J-STD-002 Condition B :Immerse the specimens in and eutectic solder at 260 \pm 5°C for 10 \pm 1S .			

公司名稱 Company Name	彩源企業股份有限公司 彩智電子科技(江西)有限公司 TZAI YUAN ENTERPRISE CO., LTD.				
品名 Product Name	車載高功率晶片電阻器 High-power Chip Resistors for Automobile				
版本 Version	A4 版	制定日期 Enactment Date	2026 年 01 月 06 日 Jan.06,2026	頁數 Page	16-8
項目 Item	規格值 Performance	試驗方法(依據 JIS C 5201-1 或 AEC-Q200 Rev D) Test methods(Conform to JIS C 5201-1 or AEC-Q200 Rev D)			
電氣特性 Electrical Characterization		<p>AEC-Q200-REV D-Test 19 GB/T 5729-2003 4.8 參照產品規格書</p> <p>按批次和樣品數量要求進行參數試驗，總結列出室溫下及最低，最高工作溫度下器件的最小值，最大值，平均值和標準偏差。</p> <p>Reference User Spec. Parametrically test per lot and sample size requirements, summary to show Min, Max, Mean and Standard deviation at room as well as Min and Max operating temperatures.</p>			
可燃性 Flammability		<p>AEC-Q200-REV D-Test 20 參照 UL-94 V-0 或 V-1 可接受。不需要電氣測試。 Reference UL-94 V-0 or V-1 are acceptable. Electrical test not required.</p>			
板彎曲 Board Flex	<p>0.5%,1% : $\pm(0.5\% + 0.05\Omega)$ 2%.5% : $\pm(1\% + 0.1\Omega)$ 0Ω : 50mΩ or less</p>	<p>AEC-Q200-REV D-Test 21 3mm deflection(0402~1210) 2mm deflection(2010~2512) 參照 AEC Q200-005 至少 60 秒的支撐時間。 Reference AEC Q200-005 60 sec minimum holding time.</p>			
端子強度 (表面貼裝元件) Terminal Strength (SMD)		<p>AEC-Q200-REV D-Test 22 參照 AEC Q200-006 器件安裝在由供應商處獲得的 PCB 板，器件已進行測試，施加一個 17.7 牛(1.8kg)的力到測試器件的側面。此外力的施加時間為 60+1 秒。同樣，這個力要慢慢地施加，以免測試器件受到震動。 Reference AEC Q200-006 With the component mounted on a PCB obtained from the Supplier with the device to be tested, apply a 17.7N(1.8Kg) force to the side of a device being tested. This force shall be applied for 60+1 seconds. Also the force shall be applied gradually as not to apply a shock to the component being tested.</p>			

公司名稱 Company Name	彩源企業股份有限公司 彩智電子科技(江西)有限公司 TZAI YUAN ENTERPRISE CO., LTD.				
品名 Product Name	車載高功率晶片電阻器 High-power Chip Resistors for Automobile				
版本 Version	A4 版	制定日期 Enactment Date	2026 年 01 月 06 日 Jan.06,2026	頁數 Page	16-9
項目 Item	規格值 Performance	試驗方法(依據 JIS C 5201-1 或 AEC-Q200 Rev D) Test methods(Conform to JIS C 5201-1 or AEC-Q200 Rev D)			
焊錫附著性 Solder ability	電極至少 95%以上新錫覆蓋。 Electrode with new solder by 95% at least.	JIS C 5201-1 4.17 項參照 Comply with 4.17 焊錫溫度：245±5℃。 浸錫時間：3~5 秒。 Test temperature of solder: 245±5℃ Dipping time in solder: 3~5 seconds			
焊錫耐熱性 Resistance to soldering heat	±(1%+0.05Ω)以內。 0R:50mΩ以下 不得有機械的損傷。 Within ±(1%+0.05Ω) 0R:50mΩ以下 No evidence of mechanical damage.	JIS C 5201-1 4.18 項參照 Comply with 4.18 260±5℃, 10±1.0 秒, 試驗後放置半小時。 260±5℃, 10±1.0 seconds After test leave for 0.5h.(見圖-2) (See Figure -2)			
電烙鐵試驗 Electric iron Test	阻值範圍：≥1Ω △ R%=±(1.0%+0.05Ω) 電極外觀無異常，無側導脫落 Resistance Range: ≥1Ω △ R%=±(1.0%+0.05Ω) No evidence of electrode damage. No sides conductive peel off.	加熱溫度：350℃±5℃，電烙鐵加熱 時間 3+1/-0 秒，取電烙鐵加熱於電極兩端后，取出靜置 60 分鐘以上，再量測其阻值變化率。 Preheating temperature: 350℃±5℃ Electric iron preheating time: 3+1/-0sec Preheat the electric iron on electrode termination, as after that step place the iron over 60mins and measure its resistance rate.			
保存條件 Preservation condition	溫度:25±10℃，濕度 60±20 RH% 保存期限：18 月 Temperature: 25±10℃, Humidity: 60±20 RH% Preservation time: Eighteen months				
運輸溫度 Transport temperature	溫度：-55℃~125℃ Temperature：-55℃~125℃， 注：低溫放置：-55℃,1h; 高溫放置：125℃,1000h Note: Low temperature exposure:-55℃,1h; High temperature exposure: 125℃,1000h				

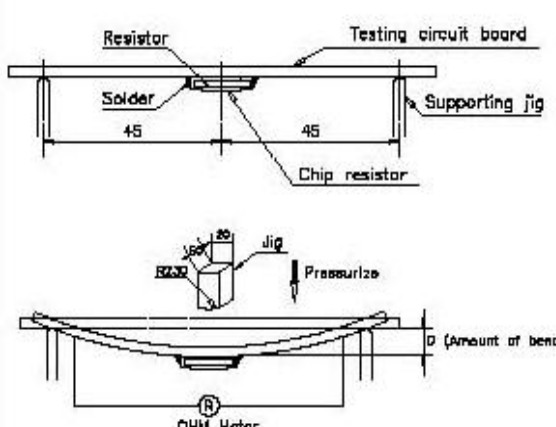
公司名稱 Company Name	彩源企業股份有限公司 彩智電子科技(江西)有限公司 TZAI YUAN ENTERPRISE CO., LTD.				
品名 Product Name	車載高功率晶片電阻器 High-power Chip Resistors for Automobile				
版本 Version	A4 版	制定日期 Enactment Date	2026 年 01 月 06 日 Jan.06,2026	頁數 Page	16-10
項目 Item 電阻值量測 Resistance measurement	規格值 Performance 溫度：20°C Temperature：20°C ±0.1%,±0.5%,±1%:±(1.0%+0.05Ω)以內 ±5%:±(3.0%+0.10Ω)以內 Within1%:±(1.0%+0.05Ω) Within5%:±(3.0%+0.10Ω)	試驗方法(依據 JIS C 5201-1 或 AEC-Q200 Rev D) Test methods(Conform to JIS C 5201-1 or AEC-Q200 Rev D) 電阻值測量標準 符合 JIS C 5201-1 4.5 規定： All of the resistance measurement according to JIS C 5201-1 4.5 standard regulations. 測定中電阻器的溫度不得有能感知到的溫度上升例如採用較低的直流電壓進行測試，並且儘可能在短時間內完成測試，判定中有產生疑義的情況下 可使用表-3 中規定的電壓 The temperature of the resistor in the test shall not be sensible of temperature rise such as a low DC voltage, and the test shall be completed in as short a time as possible. The voltage specified in Table-3 may be used in the case of doubt in the determination.			
彎折性 Bending strength	±(1%+0.05Ω)以內。 0R:50mΩ以下 Within ±(1%+0.05Ω) 0R: Within 50mΩ	6.1 項參照 Comply with 6.1 將晶片電阻焊於測試 PC 板上,在測試板中央施力下壓,於負荷下量測阻值變化率。 下壓深度(D): 0402&0603&0805=5mm 1206&1210=3mm、2010&2512=2mm Let the chip resistor on the measure board, push infliction at the middle of measure board, and measure the resistance change between pre-and-post on loading. Push depth(D): 0402&0603&0805=5mm 1206&1210=3mm、2010&2512=2mm 			

公司名稱 Company Name	彩源企業股份有限公司 彩智電子科技(江西)有限公司 TZAI YUAN ENTERPRISE CO., LTD.				
品名 Product Name	車載高功率晶片電阻器 High-power Chip Resistors for Automobile				
版本 Version	A4 版	制定日期 Enactment Date	2026 年 01 月 06 日 Jan.06,2026	頁數 Page	16-11

表-3 Table-3

額定電阻值 R Ω Resistance (Ω)	測定電壓 U(註 a) V Test Voltage (V)
$R < 10$	0.1
$10 \leq R < 100$	0.3
$100 \leq R < 1K$	1
$1K \leq R < 10K$	3
$10K \leq R < 100K$	10
$100K \leq R < 1M$	25
$1M \leq R$	50

註 1:額定電阻值未滿 10Ω，測定電壓須為規格功率的 10%以下的值，但是必須小於 0.1V。

註 2:測定電壓不可超過元件的最高電壓。

註 a:測試電壓容許誤差為：-10%~0%。

Note a: The test voltage tolerance is：-10%~0%.

● Soldering condition

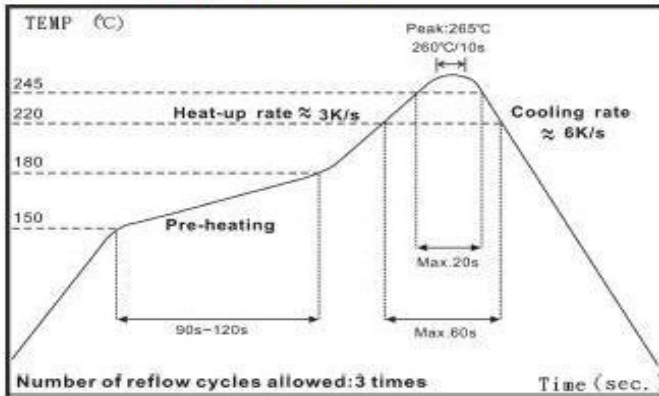

IR Reflow Soldering

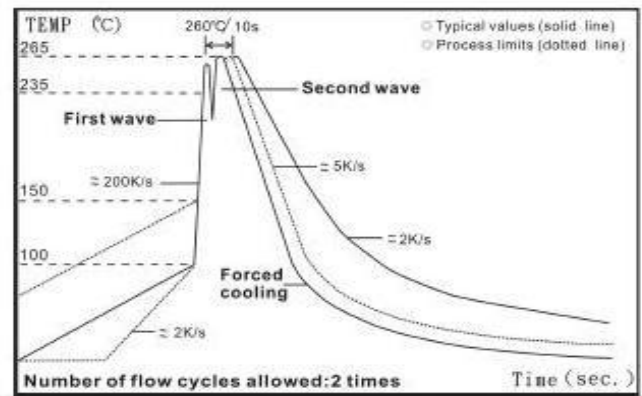

Wave Soldering (Flow Soldering)

- (1) Time of IR reflow soldering at maximum temperature point 260°C：10s
- (2) Time of wave soldering at maximum temperature point 260°C：10s

圖 2 Figure -2

公司名稱 Company Name	彩源企業股份有限公司 彩智電子科技(江西)有限公司 TZAI YUAN ENTERPRISE CO., LTD.				
品名 Product Name	車載高功率晶片電阻器 High-power Chip Resistors for Automobile				
版本 Version	A4 版	制定日期 Enactment Date	2026 年 01 月 06 日 Jan.06,2026	頁數 Page	16-12

3. 外形寸法 External dimensions

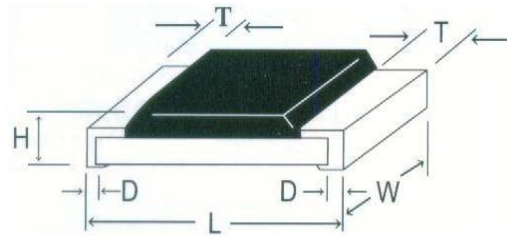

單位:mm Unit: mm

型式 Type	0402	0603	0805	1206	1210	2010	2512
公制	1005	1608	2012	3216	3225	5025	6432
L	1.0±0.1	1.6±0.1	2.0±0.15	3.1±0.15	3.1±0.1	5.0±0.15	6.35±0.2
W	0.5±0.05	0.8±0.15	1.25±0.15	1.6±0.15	2.6±0.15	2.5±0.15	3.2±0.15
H	0.35±0.05	0.45±0.1	0.55±0.1	0.55±0.1	0.55±0.1	0.55±0.1	0.55±0.1
T	0.2±0.1	0.3±0.15	0.4±0.2	0.45±0.2	0.5±0.2	0.6±0.2	0.6±0.2
D	0.25±0.1	0.3±0.2	0.4±0.2	0.5±0.20	0.5±0.20	0.6±0.2	0.6±0.2

4. 字碼表示 Marking Indication

4.1 > 1Ω字碼表示 > 1Ω Marking Indication

4.1.1 三碼表示 0603、0805、1206、1210、2010、2512 ±5% (E-24 系列)

標示規則 Marking Formula

代碼標示舉例 Code Marking Examples

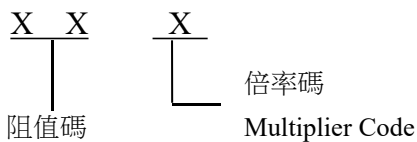

104=100KΩ
122=1.2KΩ
473=47KΩ

Resistance Code

4.1.2 四碼表示 0805、1206、1210、2010、2512 ±1% (E-96 系列)

標示規則

標示舉例

Marking Formula

Marking Examples

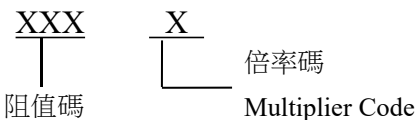

1542=15.4KΩ
22R1=22.1Ω
1020=102Ω

Resistance Code

4.1.3 特別碼表示 0603 (E-24 系列在 E-96 內未體現) 採用±5%字碼加下滑線以示區隔±1%

標示規則

標示舉例

Marking Formula

Marking Examples



123 = 12KΩ
473 = 47 KΩ

Resistance Code

公司名稱 Company Name	彩源企業股份有限公司 彩智電子科技(江西)有限公司 TZAI YUAN ENTERPRISE CO., LTD.				
品名 Product Name	車載高功率晶片電阻器 High-power Chip Resistors for Automobile				
版本 Version	A4 版	制定日期 Enactment Date	2026 年 01 月 06 日 Jan.06,2026	頁數 Page	16-13

4.1.4 三碼代碼表示 0603 ±1% (E96 系列)

標示規則 Marking Formula

X X X

阻值代碼

倍率代碼

Resistance Code

Multiplier Code

代碼標示舉例 Code Marking Examples

02C=102*10²=10.2KΩ

15E=140*10⁴=1.4MΩ

4.2 <1Ω字碼表示 <1Ω Marking Indication

4.2.1 四碼表示: 0805、1206、1210、2010、2512 ±5%、±1% (E-24.E96 系列)

標示規則

標示舉例

Marking Formula

Marking Examples

R X X X

R220 = 220mΩ

表示“0.”

阻值碼

Marking “0.”

Resistance Code

4.2.2 三碼表示: 0603 ±5%、±1% (E-24.E96 系列)

Marking Examples R22= 220mΩ

4.3 0Ω字碼表示

0603、0805、1206、1210、2010、2512 產品均以單字碼“0”表示

4.4 無字碼表示 0402 ±5%、±1% (E-24.E96 系列)

公司名稱 Company Name	彩源企業股份有限公司 彩智電子科技(江西)有限公司 TZAI YUAN ENTERPRISE CO., LTD.				
品名 Product Name	車載高功率晶片電阻器 High-power Chip Resistors for Automobile				
版本 Version	A4 版	制定日期 Enactment Date	2026 年 01 月 06 日 Jan.06,2026	頁數 Page	16-15

型式 Type	A	B	W	F	T1	T2	P
0402	0.65±0.1	1.15±0.1	8.0±0.2	3.5±0.05	-----	0.45±0.1	2.0±0.05
0603	1.10±0.1	1.9±0.1	8.0±0.2	3.5±0.05	-----	0.6±0.1	4.0±0.05
0805	1.65±0.2	2.4±0.2	8.0±0.2	3.5±0.05	-----	0.75±0.1	4.0±0.05
1206	2.0±0.2	3.6±0.2	8.0±0.2	3.5±0.05	-----	0.75±0.1	4.0±0.05
1210	2.8±0.2	3.5±0.2	8.0±0.2	3.5±0.05	-----	0.75±0.1	4.0±0.05
2010	2.9±0.2	5.5±0.2	12.0±0.1	5.5±0.5	0.2±0.05	1.0±0.1	4.0±0.05
2512	3.6±0.2	6.9±0.2	12.0±0.1	5.5±0.5	0.2±0.05	1.0±0.1	4.0±0.05

5.1 前、後導帶尺寸 Lead Dimensions :

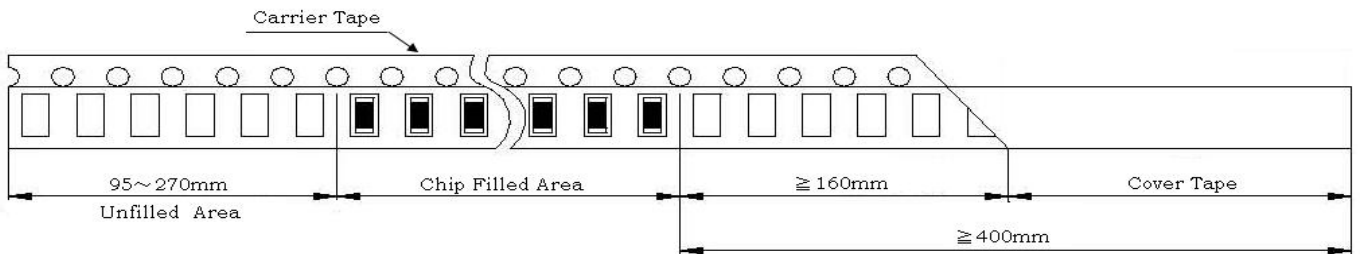

5.2 上膠帶剝離力量 Peel off Strength :

5.2.1 規格值: 0402 => 0.1~0.6N

0603、0805、1206、1210、2010、2512 => 0.1~0.8N

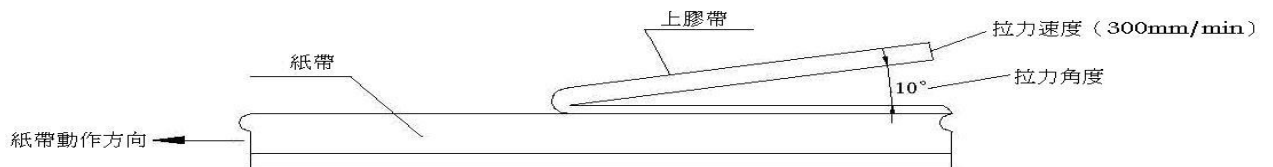

5.3 卷包 SMCH

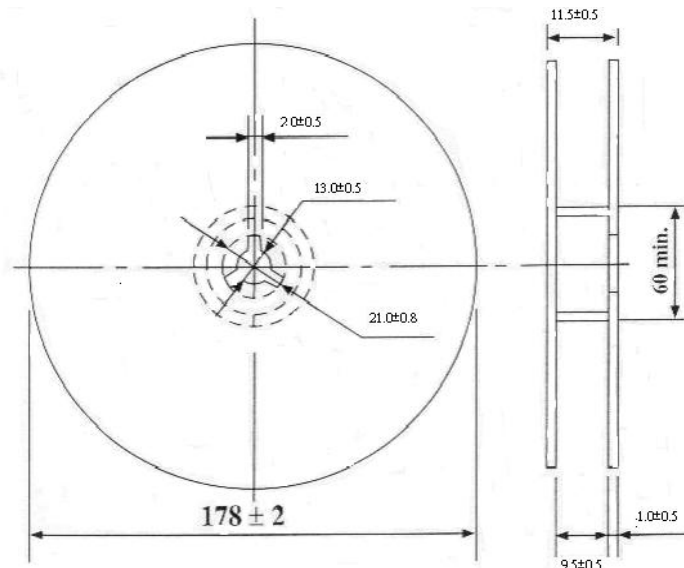

公司名稱 Company Name	彩源企業股份有限公司 彩智電子科技（江西）有限公司 TZAI YUAN ENTERPRISE CO., LTD.				
品名 Product Name	車載高功率晶片電阻器 High-power Chip Resistors for Automobile				
版本 Version	A4 版	制定日期 Enactment Date	2026 年 01 月 06 日 Jan.06,2026	頁數 Page	16-16

型式 Type	0402	0603	0805	1206	1210	2010	2512
標準包裝 Standard packing	10kpcs	5kpcs	5kpcs	5kpcs	5kpcs	4kpcs	4kpcs
包裝方式 Packing	Paper Tape					Emboss	

6. 構造圖 Structure diagram

SMCH 系列之電阻器係按下表的材料而構成:

The construction of resistor (SMCH series) shall be as follows:

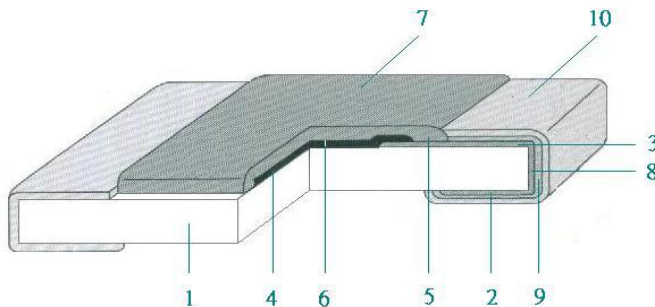

號碼 NO	構造名稱 Structure Name	內容 Material
1	陶瓷板 Ceramic substrate	使用高含鋁量的陶瓷板。 High alumina ceramic substrate is used.
2	背面導體 Outer termination	導體油墨印刷。 Conductor ink printing.
3	正面導體 Inner termination	導體油墨印刷。 Conductor ink printing.
4	電阻層 Resistor layer	混合金屬油墨印刷。 Blend metal ink printing.
5	玻璃層 Glass layer	玻璃油墨印刷。 Glass ink printing.
6	鐳射切割 Trimming cut	鐳射修正阻值。 Trimming correct Resistance.
7	保護層 Protective coat	環氧樹脂油墨印刷。 Epoxy ink printing.
8	側面電極 Side electrode	端子導體。 Terminal Conductor
9	內部電極 Internal electrode	端子鍍鎳。 Terminal electroplate nickel.
10	外部電極 External electrode	端子鍍錫。 Terminal electroplate tin.